

Suggested practice problems for Graduate Diagnostic Exam

Mechanics II

Chapt #	Exercises	Problems	
3	4, 28, 32, 38	45, 46, 50, 69, 76	
4	10, 20	34, 52	
5	4, 5, 12, 24, 26, 38, 42, 52, 55		90.96
6	2, 6, 8, 14, 34, 40, 50	56, 57, 70, 76,	
7	12, 16, 25, 26, 28,		46
8	22, 28, 36, 40, 46, 54, 60	8, 10, 108, 111	
9		70, 98	
10	12, 32, 39, 54,	74, 90	
12			

3.4. If $\vec{r} = bt^2\hat{i} + ct^3\hat{j}$, where b and c are positive constants, when does the velocity vector make an angle of 45.0° with the x - and y -axes?

3.28. On your first day at work for an appliance manufacturer, you are told to figure out what to do to the period of rotation during a washer spin cycle to triple the centripetal acceleration. You impress your boss by answering immediately. What do you tell her?

3.32. The radius of the earth's orbit around the sun (assumed to be circular) is 1.50×10^8 km, and the earth travels around this orbit in 365 days. (a) What is the magnitude of the orbital velocity of the earth, in m/s? (b) What is the radial acceleration of the earth toward the sun, in m/s^2 ? (c) Repeat parts (a) and (b) for the motion of the planet Mercury (orbit radius = 5.79×10^7 km, orbital period = 88.0 days).

3.38. Two piers, A and B , are located on a river: B is 1500 m downstream from A (Fig. 3.44). Two friends must make round trips from pier A to pier B and return. One rows a boat at a constant speed of 4.00 km/h relative to the water, the other walks on the shore at a constant speed of 4.00 km/h. The velocity of the river is 2.80 km/h in the direction from A to B . How much time does it take each person to make the round trip?

3.45. A rocket is fired at an angle from the top of a tower of height $h_0 = 50.0$ m. Because of the design of the engines, its position coordinates are of the form $x(t) = A + Bt^2$ and $y(t) = C + Dt^3$, where A , B , C , and D are constants. Furthermore, the acceleration of the rocket 1.00 s after firing is $\vec{a} = (4.00\hat{i} + 3.00\hat{j}) \text{ m/s}^2$. Take the origin of coordinates to be at the base of the tower. (a) Find the constants A , B , C , and D , including their SI units. (b) At the instant after the rocket is fired, what are its acceleration vector and its velocity? (c) What are the x - and y -components of the rocket's velocity 10.0 s after it is fired, and how fast is it moving? (d) What is the position vector of the rocket 10.0 s after it is fired?

3.46. A bird flies in a vertical circle of radius $r = 1.00$ m, and its speed is $v = 4.00$ m/s. The positive y -direction is vertically upward. At $t = 0$ the bird is at the origin. (a) Calculate the position and acceleration vectors of the bird as functions of time. (b) What is the bird's altitude (y -coordinate) as it flies over $x = 0$ for the first time after $t = 0$?

3.50. **Spiraling Up.** It is common to see birds of prey rising upward on thermals. The paths they take may be spiral-like. You can model the spiral motion as uniform circular motion combined with a constant upward velocity. Assume a bird completes a circle of radius 8.00 m every 5.00 s and rises vertically at a rate of 3.00 m/s. Determine: (a) the speed of the bird relative to the

3.69. Two tanks are engaged in a training exercise on level ground. The first tank fires a paint-filled training round with a muzzle speed of 250 m/s at 10.0° above the horizontal while advancing toward the second tank with a speed of 15.0 m/s relative to the ground. The second tank is retreating at 35.0 m/s relative to the ground, but is hit by the shell. You can ignore air resistance and assume the shell hits at the same height above ground from which it was fired. Find the distance between the tanks (a) when the round was first fired and (b) at the time of impact.

3.76. A 400.0-m-wide river flows from west to east at 30.0 m/min. Your boat moves at 100.0 m/min relative to the water no matter which direction you point it. To cross this river, you start from a dock at point A on the south bank. There is a boat landing directly opposite at point B on the north bank, and also one at point C, 75.0 m downstream from B (Fig. 3.53). (a) Where on the north shore will you land if you point your boat perpendicular to the water current, and what distance will you have traveled? (b) If you initially aim your boat directly toward point C and do not change that bearing relative to the shore, where on the north shore will you land? (c) To reach point C: (i) at what bearing must you aim your boat, (ii) how long will it take to cross the river, (iii) what distance do you travel, and (iv) what is the speed of your boat as measured by an observer standing on the river bank?

Figure 3.53 Problem 3.76.

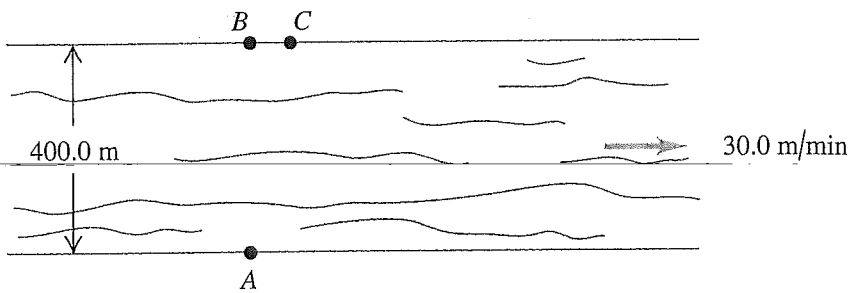

4.16. An electron (mass = 9.11×10^{-31} kg) leaves one end of a TV picture tube with zero initial speed and travels in a straight line to the accelerating grid, which is 1.80 cm away. It reaches the grid with a speed of 3.00×10^6 m/s. If the accelerating force is constant, compute (a) the acceleration, (b) the time to reach the grid, (c) the net force, in newtons. (You can ignore the gravitational force on the electron.)

4.20. An astronaut's pack weighs 17.5 N when she is on earth but only 3.24 N when she is at the surface of an asteroid. (a) What is the acceleration due to gravity on this asteroid? (b) What is the mass of the pack on the asteroid?

4.35. Two horses pull horizontally on ropes attached to a stump. The two forces \vec{F}_1 and \vec{F}_2 that they apply to the stump are such that the net (resultant) force \vec{R} has a magnitude equal to that of \vec{F}_1 and

4.52. A 4.9-N hammer head is stopped from an initial downward velocity of 3.2 m/s in a distance of 0.45 cm by a nail in a pine board. In addition to its weight, there is a 15-N downward force on the hammer head applied by the person using the hammer. Assume that the acceleration of the hammer head is constant while it is in contact with the nail and moving downward. (a) Draw a free-body diagram for the hammer head. Identify the reaction force to each action force in the diagram. (b) Calculate the downward force \vec{F} exerted by the hammer head on the nail while the hammer head is in contact with the nail and moving downward. (c) Suppose the nail is in hardwood and the distance the hammer head travels in coming to rest is only 0.12 cm. The downward forces on the hammer head are the same as on part (b). What then is the force \vec{F} exerted by the hammer head on the nail while the hammer head is in contact with the nail and moving downward?

5.4. An adventurous archaeologist crosses between two rock cliffs by slowly going hand over hand along a rope stretched between the cliffs. He stops to rest at the middle of the rope (Fig. 5.42). The rope will break if the tension in it exceeds 2.50×10^4 N, and our hero's mass is 90.0 kg. (a) If the angle θ is 10.0° , find the tension in the rope. (b) What is the smallest value the angle θ can have if the rope is not to break?

Figure 5.42 Exercise 5.4.

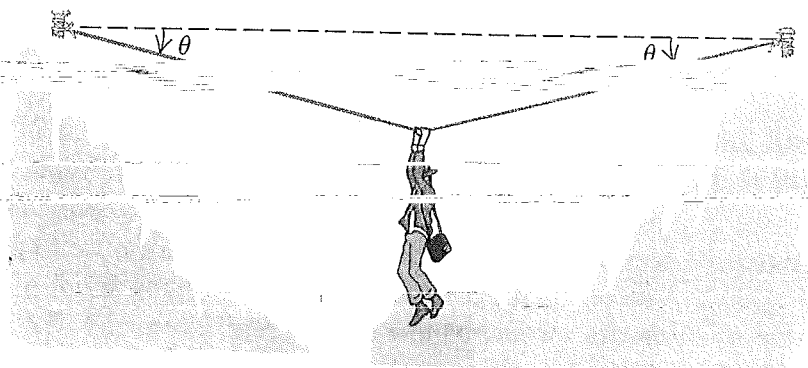

5.5. A picture frame hung against a wall is suspended by two wires attached to its upper corners. If the two wires make the same angle with the vertical, what must this angle be if the tension in each wire is equal to 0.75 of the weight of the frame? (Ignore any friction between the wall and the picture frame.)

5.12. In Fig. 5.46 the weight w is 60.0 N. (a) What is the tension in the diagonal string? (b) Find the magnitudes of the horizontal forces \vec{F}_1 and \vec{F}_2 that must be applied to hold the system in the position shown.

Figure 5.46 Exercise 5.12.

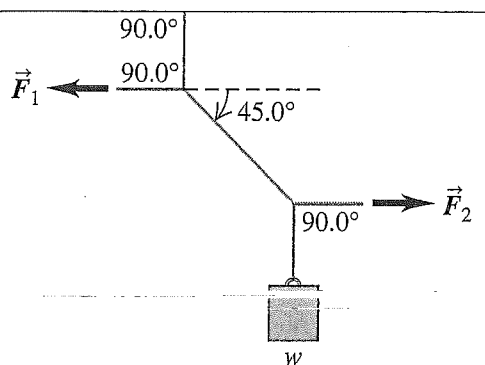

5.24. **Apparent Weight.** A 550-N physics student stands on a scale on a moving (including the student) elevator that is supported by a cable. As the elevator starts moving, the scale reads 450 N. (a) Find the acceleration of the elevator (magnitude and direction). (b) What is the acceleration if the scale reads 670 N? (c) If the scale reads zero, should the student worry? Explain. (d) What is the tension in the cable in parts (a) and (c)?

5.26. A 2540-kg test rocket is launched vertically from the launch pad. Its fuel (of negligible mass) provides a thrust force so that its vertical velocity as a function of time is given by $v(t) = At + Bt^2$, where A and B are constants and time is measured from the instant the fuel is ignited. At the instant of ignition, the rocket has an upward acceleration of 1.50 m/s^2 and 1.00 s later an upward velocity of 2.00 m/s . (a) Determine A and B , including their SI units. (b) At 4.00 s after fuel ignition, what is the acceleration of the rocket, and (c) what thrust force does the burning fuel exert on it, assume no air resistance? Express the thrust in newtons and as a multiple of the rocket's weight. (d) What was the initial thrust due to the fuel?

5.38. **Rolling Friction.** Two bicycle tires are set rolling with the same initial speed of 3.50 m/s on a long, straight road, and the distance each travels before its speed is reduced by half is measured. One tire is inflated to a pressure of 40 psi and goes 18.1 m; the other is at 105 psi and goes 92.9 m. What is the coefficient of rolling friction μ_r for each? Assume that the net horizontal force is due to rolling friction only.

5.42. A 25.0-kg box of textbooks rests on a loading ramp that makes an angle α with the horizontal. The coefficient of static friction is 0.25 and the coefficient of kinetic friction is 0.15. (a) As the angle α is increased, find the minimum angle at which the box starts to slip. (b) At this angle, find the acceleration once the box has begun to move. (c) At this angle, how fast will the box be moving after it has slid 5.0 m along the loading ramp?

5.52. The “Giant Swing” at a county fair consists of a vertical central shaft with a number of horizontal arms attached at its upper end (Fig. 5.57). Each arm supports a seat suspended from a cable 5.00 m long, the upper end of the cable being fastened to the arm at

Figure 5.57 Exercise 5.52.

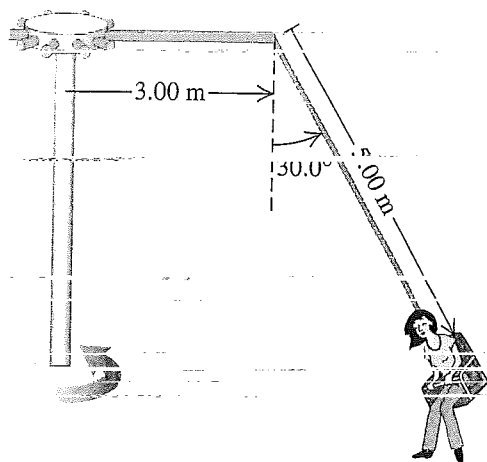

a point 3.00 m from the central shaft. (a) Find the time of one revolution of the swing if the cable supporting a seat makes an angle of 30.0° with the vertical. (b) Does the angle depend on the weight of the passenger for a given rate of revolution?

5.55 Rotating Space Station

in outer space is that they are apparently weightless. One way around this problem is to design a space station that spins about its center at a constant rate. This creates “artificial gravity” at the outside rim of the station. (a) If the diameter of the space station is 800 m, how many revolutions per minute are needed for the “artificial gravity” acceleration to be 9.80 m/s^2 ? (b) If the space station is a waiting area for travelers going to Mars, it might be desirable to simulate the acceleration due to gravity on the Martian surface (3.70 m/s^2). How many revolutions per minute are needed in this case?

5.90. Friction in an Elevator. You are riding in an elevator on the way to the 18th floor of your dormitory. The elevator is accelerating upward with $a = 1.90 \text{ m/s}^2$. Beside you is the box containing your new computer; the box and its contents have a total mass of 28.0 kg. While the elevator is accelerating upward, you push horizontally on the box to force it at constant speed toward the elevator door. If the coefficient of kinetic friction between the box and the elevator floor is $\mu_k = 0.32$, what magnitude of force must you apply?

5.96 Banked Curve II Consider a wet roadway banked at an angle

Example 5.25 (Section 5.4) where there is a coefficient of static friction of 0.30 and a coefficient of kinetic friction of 0.25 between the tires and the roadway. The radius of the curve is $R = 50 \text{ m}$.

(a) If the banking angle is $\beta = 25^\circ$, what is the *maximum* speed the automobile can have before sliding *up* the banking? (b) What is the *minimum* speed the automobile can have before sliding *down* the banking?

6.2. A tow truck pulls a car 5.00 km along a horizontal roadway using a cable having a tension of 850 N. (a) How much work does the cable do on the car if it pulls horizontally? If it pulls at 35.0° above the horizontal? (b) How much work does the cable do on the tow truck in both cases of part (a)? (c) How much work does gravity do on the car in part (a)?

6.6. Two tugboats pull a disabled supertanker. Each tug exerts a constant force of 1.80×10^6 N, one 14° west of north and the other 14° east of north, as they pull the tanker 0.75 km toward the north. What is the total work they do on the supertanker?

6.8. A loaded grocery cart is rolling across a parking lot in a strong wind. You apply a constant force $\vec{F} = (30 \text{ N})\hat{i} - (40 \text{ N})\hat{j}$ to the cart as it undergoes a displacement $\vec{s} = (-9.0 \text{ m})\hat{i} - (3.0 \text{ m})\hat{j}$. How much work does the force you apply do on the grocery cart?

6.14. A 4.80-kg watermelon is dropped from rest from the roof of a 25.0-m tall building and feels no appreciable air resistance. (a) Calculate the work done by gravity on the watermelon during its displacement from the roof to the ground. (b) Just before it strikes the ground, what is the watermelon's (i) kinetic energy and (ii) speed? (c) Which of the answers in parts (a) and (b) would be *different* if there were appreciable air resistance?

6.34. Leg Presses. As part of your daily workout, you lie on your back and push with your feet against a platform attached to two stiff springs arranged side by side so that they are parallel to each other. When you push the platform, you compress the springs. You do 30.0 J of work when you compress the springs 0.200 m from their uncompressed length. (a) What magnitude of force must you apply to hold the platform in this position? (b) How much *additional* work must you do to move the platform 0.200 m farther, and what maximum force must you apply?

6.40. Half of a Spring. (a) Suppose you cut a massless ideal spring in half. If the full spring had a force constant k , what is the force constant of each half, in terms of k ? (*Hint:* Think of the original spring as two equal halves, each producing the same force as the entire spring. Do you see why the forces must be equal?) (b) If you cut the spring into three equal segments instead, what is the force constant of each one, in terms of k ?

6.50. An elevator has mass 600 kg, not including passengers. The elevator is designed to ascend at constant speed a vertical distance of 20.0 m (five floors) in 16.0 s, and it is driven by a motor that can provide up to 40 hp to the elevator. What is the maximum number of passengers that can ride in the elevator? Assume that an average passenger has mass 65.0 kg.

6.56. A Near-Earth Asteroid. On April 13, 2029 (Friday the 13th!), the asteroid 99942 Apophis will pass within 18,600 mi of the earth—about $1/13$ the distance to the moon! It has a density of 2600 kg/m^3 , can be modeled as a sphere 320 m in diameter and will be traveling at 12.5 km/s . (a) If, due to a small disturbance in its orbit, the asteroid were to hit the earth, how much kinetic energy would it deliver? (b) The largest nuclear bomb ever tested by the United States was the “Castle/Bravo” bomb, having a yield of 15 megatons of TNT. (A megaton of TNT releases $4.184 \times 10^{15} \text{ J}$ of energy.) How many Castle/Bravo bombs would be equivalent to the energy of Apophis?

6.57. A luggage handler pulls a 20.0-kg suitcase up a ramp inclined at 25.0° above the horizontal by a force \vec{F} of magnitude 140 N that acts parallel to the ramp. The coefficient of kinetic friction between the ramp and the incline is $\mu_k = 0.300$. If the suitcase travels 3.80 m along the ramp, calculate (a) the work done on the suitcase by the force F ; (b) the work done on the suitcase by the gravitational force; (c) the work done on the suitcase by the normal force; (d) the work done on the suitcase by the friction force; (e) the total work done on the suitcase; (f) If the speed of the suitcase is zero at the bottom of the ramp, what is its speed after it has traveled 3.80 m along the ramp?

6.70. Proton Bombardment. A proton with mass $1.67 \times 10^{-27} \text{ kg}$ is propelled at an initial speed of $3.00 \times 10^5 \text{ m/s}$ directly toward a uranium nucleus 5.00 m away. The proton is repelled by the uranium nucleus with a force of magnitude $F = \alpha/x^2$, where x is the separation between the two objects and $\alpha = 2.12 \times 10^{-26} \text{ N} \cdot \text{m}^2$. Assume that the uranium nucleus remains at rest.

(a) What is the speed of the proton when it is $8.00 \times 10^{-10} \text{ m}$ from the uranium nucleus? (b) As the proton approaches the uranium nucleus, the repulsive force slows down the proton until it comes momentarily to rest, after which the proton moves away from the uranium nucleus. How close to the uranium nucleus does the proton get? (c) What is the speed of the proton when it is again 5.00 m away from the uranium nucleus?

6.76. The spring of a spring gun has force constant $k = 400 \text{ N/m}$ and negligible mass. The spring is compressed 6.00 cm, and a ball with mass 0.0300 kg is placed in the horizontal barrel against the compressed spring. The spring is then released, and the ball is propelled out the barrel of the gun. The barrel is 6.00 cm long, so the ball leaves the barrel at the same point that it loses contact with the spring. The gun is held so the barrel is horizontal. (a) Calculate the speed with which the ball leaves the barrel if you can ignore friction. (b) Calculate the speed of the ball as it leaves the barrel if a constant resisting force of 6.00 N acts on the ball as it moves along the barrel. (c) For the situation in part (b), at what position along the barrel does the ball have the greatest speed, and what is that speed? (In this case, the maximum speed does not occur at the end of the barrel.)

7.12. Tarzan and Jane. Tarzan, in one tree, sights Jane in another tree. He grabs the end of a vine with length 20 m that makes an angle of 45° with the vertical, steps off his tree limb, and swings down and then up to Jane's open arms. When he arrives, his vine makes an angle of 30° with the vertical. Determine whether he gives her a tender embrace or knocks her off her limb by calculating Tarzan's speed just before he reaches Jane. You can ignore air resistance and the mass of the vine.

7.16. An ideal spring of negligible mass is 12.00 cm long when nothing is attached to it. When you hang a 3.15-kg weight from it, you measure its length to be 13.40 cm. If you wanted to store 10.0 J of potential energy in this spring, what would be its total length? Assume that it continues to obey Hooke's law.

7.25. You are asked to design a spring that will give a 1160-kg satellite a speed of 2.50 m/s relative to an orbiting space shuttle.

Your spring is to give the satellite a maximum acceleration of $5.00g$. The spring's mass, the recoil kinetic energy of the shuttle, and changes in gravitational potential energy will all be negligible. (a) What must the force constant of the spring be? (b) What distance must the spring be compressed?

7.26. A 75-kg roofer climbs a vertical 7.0-m ladder to the flat roof of a house. He then walks 12 m on the roof, climbs down another vertical 7.0-m ladder, and finally walks on the ground back to his starting point. How much work is done on him by gravity (a) as he climbs up; (b) as he climbs down; (c) as he walks on the roof and on the ground? (d) What is the total work done on him by gravity during this round trip? (e) On the basis of your answer to part (d), would you say that gravity is a conservative force? Explain.

7.28. In an experiment, one of the forces exerted on a proton is $\vec{F} = \alpha x^2 \hat{i}$, where $\alpha = 12 \text{ N/m}^2$. (a) How much work does \vec{F} do when the proton moves along the straight-line path from the point

(0.10 m, 0) to the point (0.10 m, 0.40 m)? (b) Along the straight-line path from the point (0.10 m, 0) to the point (0.50 m, 0)? (c) Along the straight-line path from the point (0.50 m, 0) to the point (0.10 m, 0)? (d) Is the force \vec{F} conservative? Explain. If \vec{F} is conservative, what is the potential-energy function for it? Let $U = 0$ when $x = 0$.

7.46. Riding a Loop-the-Loop.

Figure 7.32 Problem 7.46.

A car in an amusement park ride rolls without friction around the track shown in Fig. 7.32. It starts from rest at point A at a height h above the bottom of the loop. Treat the car as a particle.



(a) What is the minimum value of h (in terms of R) such that the car moves around the loop without falling off at the top (point B)? (b) If $h = 3.50R$ and $R = 20.0 \text{ m}$, compute the speed, radial acceleration,

8.22. An atomic nucleus suddenly bursts apart (fissions) into two pieces. Piece A, of mass m_A , travels off to the left with speed v_A . Piece B, of mass m_B , travels off to the right with speed v_B . (a) Use conservation of momentum to solve for v_B in terms of m_A , m_B , and v_A . (b) Use the results of part (a) to show that $K_A/K_B = m_B/m_A$, where K_A and K_B are the kinetic energies of the two pieces.

asteroids of equal masses the

asteroid A, which was hit

remained at 45.0 m/s

moving at 70.0 m/s,

45.0 m/s

45.0 m/s

45.0 m/s

45.0 m/s

45.0 m/s

45.0 m/s

45.0 m/s

45.0 m/s

45.0 m/s

45.0 m/s

45.0 m/s

45.0 m/s

45.0 m/s

45.0 m/s

45.0 m/s

45.0 m/s

45.0 m/s

45.0 m/s

45.0 m/s

45.0 m/s

45.0 m/s

45.0 m/s

45.0 m/s

45.0 m/s

45.0 m/s

45.0 m/s

45.0 m/s

45.0 m/s

45.0 m/s

45.0 m/s

45.0 m/s

45.0 m/s

45.0 m/s

45.0 m/s

45.0 m/s

45.0 m/s

45.0 m/s

45.0 m/s

45.0 m/s

45.0 m/s

45.0 m/s

45.0 m/s

45.0 m/s

45.0 m/s

45.0 m/s

45.0 m/s

45.0 m/s

45.0 m/s

8.38. Bird Defense. To protect their young in the nest, peregrine falcons will fly into birds of prey (such as ravens) at high speed. In one such episode, a 600-g falcon flying at 20.0 m/s hit a 1.50-kg raven flying at 9.0 m/s. The falcon hit the raven at right angles to its original path and bounced back at 5.0 m/s. (These figures were estimated by the author as he watched this attack occur in northern New Mexico.) (a) By what angle did the falcon change the raven's direction of motion? (b) What was the raven's speed right after the collision?

8.40. You and your friends are doing physics experiments on a frozen pond that serves as a frictionless, horizontal surface. Sam, with mass 80.0 kg, is given a push and slides eastward. Abigail

is moving at 6.00 m/s east. Abigail is moving at 6.00 m/s east before the collision? (b) By how much did the total kinetic energy of the two people decrease during the collision?

8.46. You are at the controls of a particle accelerator, sending a beam of 1.50×10^7 m/s protons (mass m) at a gas target of an unknown element. Your detector tells you that some protons bounce straight back after a collision with one of the nuclei of the unknown element. All such protons rebound with a speed of 1.20×10^7 m/s. Assume that the initial speed of the target nucleus is negligible and the collision is elastic. (a) Find the mass of one nucleus of the unknown element. Express your answer in terms of the proton mass m . (b) What is the speed of the unknown nucleus immediately after such a collision?

8.54. A system consists of two particles. At $t = 0$ one particle is at

for 1.70 s, while burning 0.0125 kg of propellant. It has a maximum thrust of 13.3 N. The initial mass of the engine plus propel-

average thrust? (b) Calculate the relative speed of the exhaust gases, assuming it is constant. (c) Assuming that the relative speed of the exhaust gases is constant, find the final speed of the engine if it was attached to a very light frame and fired from rest in gravity-free outer space.

8.80. A 20.00-kg lead sphere is hanging from a hook by a thin wire 3.50-m long, and is free to swing in a complete circle. Suddenly it is struck horizontally by a 5.00-kg steel dart that embeds itself in the lead sphere. What must be the minimum initial speed of the dart so that the combination makes a complete circular loop after the collision?

8.100. A 45.0-kg woman stands up in a 60.0-kg canoe 5.00 m long. She walks from a point 1.00 m from one end to a point 1.00 m from the other end (Fig. 8.48). If you ignore resistance to motion of the canoe in the water, how far does the canoe move during this process?

Figure 8.48 Problem 8.100.

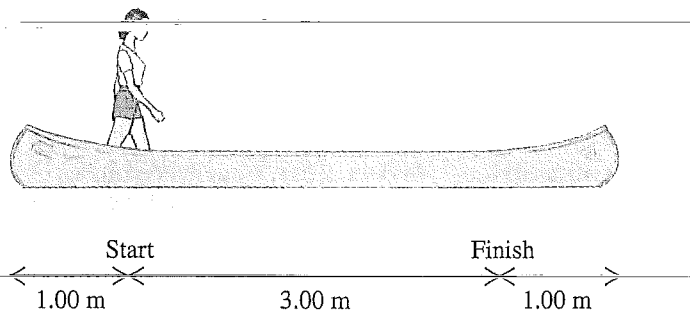

8.108. Binding Energy of the Hydrogen Molecule. When two hydrogen atoms of mass m combine to form a diatomic hydrogen molecule (H_2), the potential energy of the system after they combine is $-\Lambda$, where Λ is a positive quantity called the binding energy of the molecule. (a) Show that if only two hydrogen atoms, it is impossible to form an H_2 molecule because momentum and energy cannot simultaneously be conserved. (Hint: If you can show this to be true in one frame of reference, then it is true in all frames of reference. Can you see why?)

... atoms has speed 1.00×10^5 m/s, and they are approaching at 120° angles so that at any instant, the atoms lie at the corners of an equilateral triangle. Find the speeds of the H_2 molecule and of the single hydrogen atom that remains after the collision. The binding energy of H_2 is $\Lambda = 7.23 \times 10^{-19}$ J, and the mass of the hydrogen atom is 1.67×10^{-27} kg.

stage rocket has total mass 12,000 kg, of which 9000 kg is fuel. The total mass of the second stage is 1000 kg, of which 700 kg is fuel. Assume that the relative speed v_{ex} of ejected material is constant, and ignore any effect of gravity. (The effect of gravity is small during the firing period if the rate of fuel consumption is large.) (a) Suppose the entire fuel supply carried by the two-stage rocket is utilized in a single-stage rocket with the same total mass of 13,000 kg. In terms of v_{ex} , what is the speed of the rocket, starting from rest, when its fuel is exhausted? (b) For the two-stage rocket, what is the speed when the fuel of the first stage is exhausted? This speed then becomes the initial speed of the second stage. At this point, the second stage separates from the first stage. (c) What is the final speed of the second stage? (d) What value of v_{ex} is required to give the second stage of the rocket a speed of 7.00 km/s?

9.70. Engineers are designing a system by which a falling mass m imparts kinetic energy to a rotating uniform drum to which it is attached by thin, very light wire wrapped around the rim of the drum (Fig. 9.34). There is no appreciable friction in the axle of the drum, and everything starts from rest. This system is being tested on earth, but it is to be used on Mars, where the acceleration due to gravity is 3.71 m/s^2 . In the earth tests, when m is set to 15.0 kg and allowed to fall through 5.00 m, it gives 250.0 J of kinetic energy to the drum. (a) If the system is operated on Mars, through what distance would the 15.0-kg mass have to fall to give the same amount of kinetic energy to the drum? (b) How fast would the 15.0-kg mass be moving on Mars just as the drum gained 250.0 J of kinetic energy?

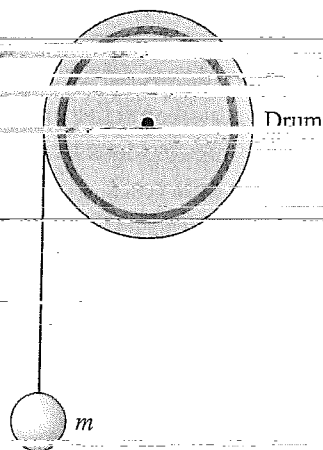

9.98. Neutron Stars and Super-Crab Nebula at a rate of about $5 \times 10^{31} \text{ W}$ about 10^5 times the rate at which the sun radiates energy. The Crab Nebula obtains its energy from the rotational kinetic energy of a rapidly spinning

1054 A.D. Energy is released by the supernovae predict that the neutron star in the Crab Nebula has a mass about 1.4 times that of the sun. Modeling the neutron star as a

10.12. A stone is suspended from the free end of a wire that is wrapped around the outer rim of a pulley, similar to what is shown in Fig. 10.10. The pulley is a uniform disk with mass 10.0 kg and radius 50.0 cm and turns on frictionless bearings. You measure that the stone travels 12.6 m in the first 3.00 s starting from rest. Find (a) the mass of the stone and (b) the tension in the wire.

10.32. An airplane propeller is 2.08 m in length (from tip to tip) and has a mass of 117 kg. When the airplane's engine is first started, it applies a constant torque of 1950 N·m to the propeller, which starts from rest. (a) What is the angular acceleration of the propeller? Model the propeller as a slender rod and see Table 9.2. (b) What is the propeller's angular speed after making 5.00 revolutions? (c) How much work is done by the engine during the first 5.00 revolutions? (d) What is the average power output of the engine during the first 5.00 revolutions? (e) What is the instantaneous power output of the motor at the instant that the propeller has turned through 5.00 revolutions?

10.39. Under some circumstances, a star can collapse into an extremely dense object made mostly of neutrons and called a *neutron star*. The density of a neutron star is roughly 10^{14} times as great as that of ordinary solid matter. Suppose we represent the star as a uniform, solid, rigid sphere, both before and after the collapse. The star's initial radius was 7.0×10^5 km (comparable to our sun); its final radius is 16 km. If the original star rotated once in 30 days, find the angular speed of the neutron star.

10.57. An experimental bicycle wheel is placed on a test stand that it is free to turn on its axle. If a constant net torque of 5.00 N·m is applied to the tire for 2.00 s, the angular speed of the tire increases from 0 to 100 rev/min. The external torque is then removed, and the wheel slows to a stop in 125 s. Compute (a) the moment of inertia of the wheel about the rotation axis, (b) the friction torque, (c) the total number of rotations made by the wheel in the 125-s time interval.

10.74. A uniform marble rolls without slipping down the path

Figure 10.59 Problem 10.74

shown in Fig. 10.59, starting from rest. (a) Find the minimum height h required for the marble not to fall into the pit. (b) The moment of inertia of the marble depends on its radius. Explain why the answer to part (a) does not depend on the radius of the marble. (c) Solve part (a) for a block that slides without friction instead of the rolling marble. How does the minimum h in this case compare to the answer in part (a)?

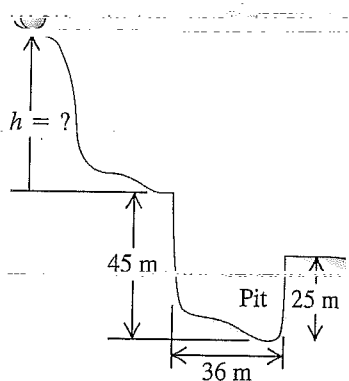

10.90. Neutron Star Glitches Occasionally, a rotating neutron star (see Exercise 10.39) undergoes a sudden and unexpected speedup called a *glitch*. One explanation is that a glitch occurs when the crust of the neutron star settles slightly, decreasing the moment of inertia. Suppose that the angular speed of a neutron star increases from ω_0 to $\omega_0 + \Delta\omega$, where $\Delta\omega/\omega_0 = 2.01 \times 10^{-6}$. If the radius of the neutron star before the glitch was 11 km, by how much did its radius decrease in the starquake? Assume that the neutron star is a uniform sphere.